

TECHNICAL DATA SHEET

90° 450X450 AMBULANT GRAB RAIL



PRODUCT CODE

SAB-GR-AMB-SSS

MATERIALS AND PRODUCT FEATURES

The Sabre range of grab rails and back rests have been developed to meet the safety requirements for those with physical disabilities. Our products comply with the Australian standard AS1428.1-2009. All mounting plates provide five fixings positions to ensure easy mounting to various building surfaces and have 77mm diameter concealed twist and lock covers. The twist and locks mechanism makes it difficult for the covers to come loose when installed correctly.

TECHNICAL DETAILS

- Rails made from secure 1.2mm thick, 32mm diameter 304 stainless steel tube.
- All mounting plates provide five fixings positions
- Mounting plates have 77mm diameter concealed twist and lock covers.
- Fixings: 10g 50mm Stainless Steel Phillips Pan Head Screws x10

TWIST AND LOCK ROSE COVER

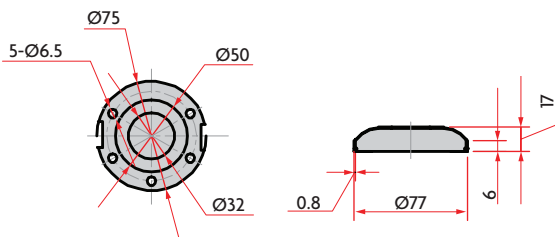
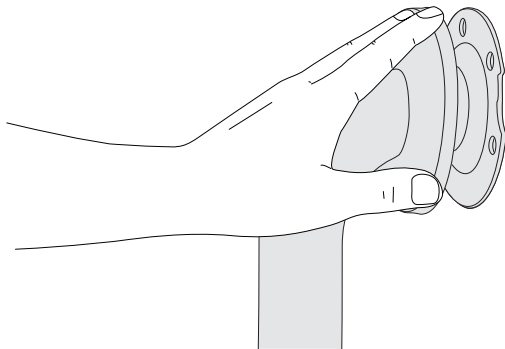

DIMENSIONS

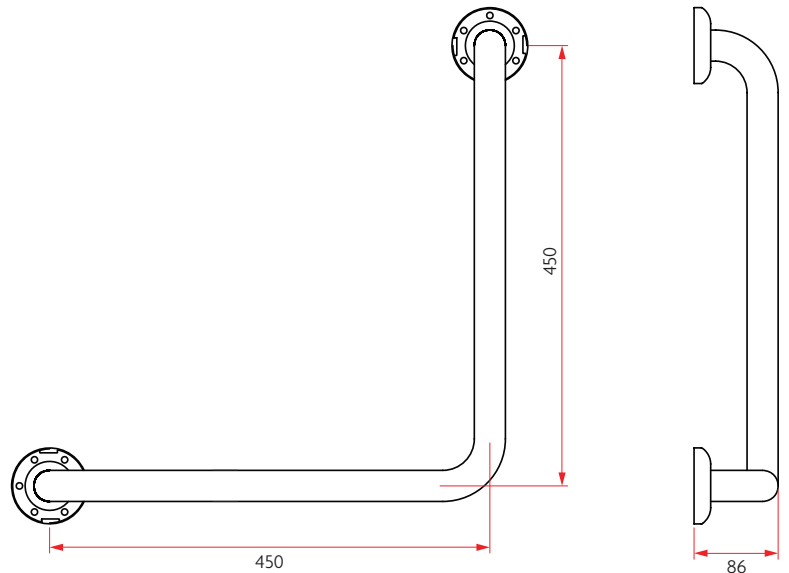

RELATED PRODUCTS



SAB-BS-FAT-BW



SAB-BS-MAT-BW



SAB-BS-UAT-BW

INSTALLATION

It's important to note that the appropriate wall preparation is made for the locations of each individual fixing point. This will ensure that the rail is firmly secured to the wall to support the intended use of this product. The installer should be familiar with the relevant building code standards to make sure the rails is installed in the correct position.