

TECHNICAL DATA SHEET BR01 BACKREST - STRAIGHT

AS1428.1 COMPLIANT

STAINLESS STEEL

5 YEAR FINISH WARRANTY

PRODUCT CODE

SAB-BR01-SSS

PRODUCT FEATURES

The SABRE backrest has been developed to meet the safety requirements to assist those with physical disabilities while maintaining compliance with the Australian Standard AS1428.1. The rails are projection adjustable to comply with dimensional installation requirements.

All rails are made from $\varnothing 32 \times 1.2$ mm 304 Stainless Steel tubing with two stainless steel fixing blocks each with 6 fixing positions. The comfortably padded backrest seat is made from a polyurethane which is hygienic and easy to clean.

TECHNICAL DETAILS

AS1428.1 Compliant	Yes
Material	Rails, Covers and Blocks – 304 Stainless Steel Backrest Seat – Polyurethane
Finish	Covers and Rails – Satin Stainless Steel Backrest Seat – White Polyurethane
Rails	$\varnothing 32$ mm x 1.2mm 304 Stainless Steel Tube
Fixing	2 Rectangular fixing blocks each with 3 fixing positions
Covers	2 Rectangular cover plates for fixing blocks
Fixing Screws	Not included

INSTALLATION

It's important to note that the proper wall preparation is made for the location of each fixing point and appropriate fixings and fixing methods are used to ensure that the fixing blocks are firmly secured to the wall to support the intended use of the product.

When AS1428.1 Design for Access and Mobility compliance is required, the installer must ensure all backrest installation criteria for this standard are met. Trim the rail tubes to achieve the required wall projection measured from the front of the WC Pan to the front of the backrest seat.

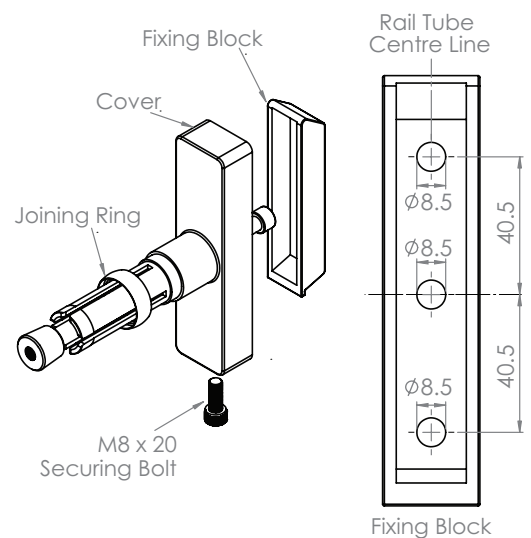
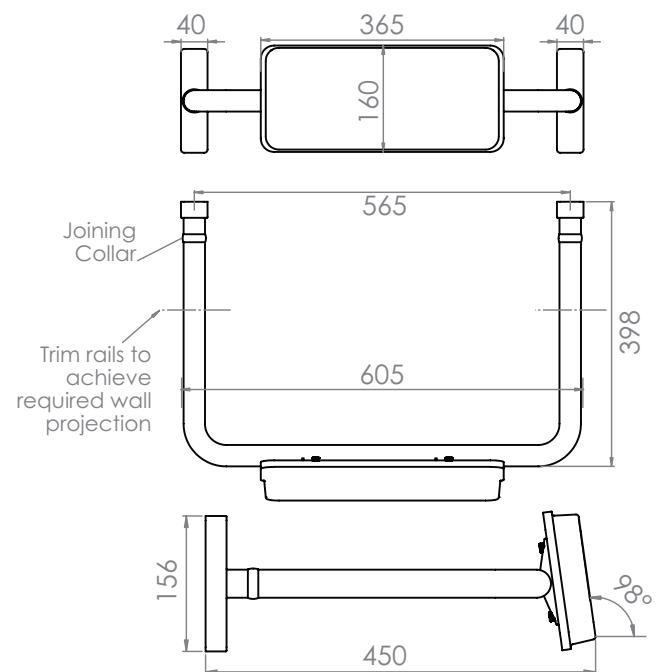

This Technical Data Sheet was last updated on 12th December 2024.